

Translation of the original operating instructions



Grease supply system AX-2000 / 230 V AC



ABNOX AG

Langackerstrasse 25
CH-6330 Cham
Schweiz

Tel. +41 (0) 41 780 44 55
Fax +41 (0) 41 780 44 50

E-Mail info@abnox.com
Internet www.abnox.com

© copyright of the publisher

This document may be copied, translated or made accessible to third parties with the express approval of the publisher only.

About the operating instructions

These operating instructions are part of the system/device and are included in the scope of delivery in the event of a resale.

EC declaration of conformity

according to the EU Machinery Directive 2006/42/EC, Annex II 1. A

Person established in the Community authorised to compile the technical file

Manufacturer

ABNOX AG
Langackerstrasse 25
CH – 6330 Cham

Peter Barmettler
ABNOX AG
Langackerstrasse 25
CH – 6330 Cham

Description and identification of the machinery

Product / Article	Electric-operated grease supply systems AX-2000
Type	AX-2000-1, AX-2000-2, AX-2000-3, AX-2000-4
Project number	PRJ-2013-08-00001
Commercial name	AX-2000 230V AC

It is expressly declared that the machinery fulfils all relevant provisions of the following EU Directives.

2006/42/EC	Directive 2006/42/EC of the European Parliament and of the Council of 17 May 2006 on machinery, and amending Directive 95/16/EC (recast) (1)
2004/108/EC	Directive 2004/108/EC of the European Parliament and of the Council of 15 December 2004 on the approximation of the laws of the Member States relating to electromagnetic compatibility and repealing Directive 89/336/EEC
2006/95/EC	Directive 2006/95/EC of the European Parliament and of the Council of 12 December 2006 on the harmonisation of the laws of Member States relating to electrical equipment designed for use within certain voltage limits (codified version) (1)

Reference to the harmonised standards used, as referred to in Article 7 (2)

EN 60204-1:2006-06	Safety of machinery - Electrical equipment of machines - Part 1: General requirements
EN ISO 12100:2010-11	Safety of machinery - General principles for design - Risk assessment and risk reduction (ISO 12100:2010)

Cham, 28.08.2013
Place, Date



Signature
Roberto Bernich
Quality Manager

1 Inhaltsverzeichnis

2	Safty information	4
2.1	Intended use	4
2.2	Obligations of the operator	4
2.3	Basic safety information	5
2.4	Safety and hazard symbols	5
2.5	Safety information for using the product	6
2.6	Special types of hazard	6
2.6.1	Electrical energy	6
2.6.2	Hydraulic energy	6
2.7	Maintenance, Servicing and Troubleshooting	6
2.8	Warranty and liability	7
3	Product description	7
3.1	Technical details	7
3.2	Overall view AX-2000	8
3.3	Application	8
3.4	Identification	8
3.5	Function	9
4	Packaging and transport	9
4.1	Transport damage	9
5	Training	9
6	Assembly – setting up/ installation	10
7	Initial commissioning	10
8	Operating elements	11
9	Finding and fixing faults	11
10	Customer service/ support	12
11	Maintenance	12
11.1	Maintenance plan	12
12	Decommissioning	12
12.1	Short-term interruption	12
12.2	Long-term interruption	13
13	Spare parts	13
14	Retirement of the product	13
15	Resale	13
16	Optionen	13

2 Safty information

Please read through this operating manual carefully to make yourself familiar with the safe and efficient operation of this product. Keep this handbook for reference purposes.

This operating manual contains important regulations and information for the safe and professional operation of the equipment/the device. It is also meant to help the operating and maintenance personnel to avoid hazards, to reduce repair costs and failure times and to increase the reliability and the lifespan of the equipment/the device. Therefore it is very important to guarantee access to this document for anyone who is assigned with the support of the equipment/the device.

2.1 Intended use

The equipment/the device may be used only in the intended operating conditions. Any other use over and above that is not deemed as intended use. The manufacturer shall not be liable for any damages resulting from unintended use.

The following are also part of intended use:

- Following and adhering to all the information from the operating manual.
- Adherence to the inspection and maintenance work.



Improper use

The manufacturer shall not be liable for any damages that may be attributed to an improper use of the equipment/the device.

2.2 Obligations of the operator

By the person responsible for safety it shall be ensured that:

- Only qualified personnel is assigned to work with the machinery and devices
- These persons always have among other the operating manual and other documents of the product documents when doing the job and obligated to follow these documents.
- Unqualified personnel are not permitted to work with the equipment
- The rules and regulations for accident prevent that are applicable for the place of use and the adherence to the maintenance work are followed.

Only qualified personnel who due to their education, experience and training and knowledge about the relevant standards, regulations, accident prevention rules and operating conditions have been authorised by the person responsible for the safety of the equipment to carry out necessary tasks and who know and can avoid the hazards may be permitted to work with equipment.

The responsibilities of the personnel are clearly defined for the assembly, commissioning, operation, setting-up, maintenance, storage and repair.

Trainees may work at the equipment only under the supervision of qualified personnel.

The safety information and safety requirements are described below and with this safety information no claim is raised on the completeness of the information.

2.3 Basic safety information

The following are the basic requirements for the safe handling and trouble-free operation of this equipment/device:

- May not be used alienated from its purpose.
- No modifications may be carried out at the equipment/device. Should this happen, then the customer shall have the sole responsibility. For desired modifications please speak to ABNOX AG.
- The safe operational condition of the equipment/device should be guaranteed at all times. An inspection on the function and damages should be conducted regularly by the qualified personnel. On request we will conduct device training to bring your personnel to the required level of knowledge.
- The customer is responsible for complying with all the necessary safety measures.
- During maintenance work disconnect the device from the compressed air / lubricant pipe.
- All the pipes, hoses and screws must be regularly inspected for leaks and externally recognisable damages. Remove damages by the qualified personnel immediately!
- The cleanliness and clear arrangement of the work area at and around the equipment/device should be ensured and inspected through regular checks.
- The rules and regulations for accident prevention applicable for the place of use must be followed.
- Safety equipments may be removed only after bringing the equipment to a standstill and protecting the equipment/device from being started again.
- Before each operation of the equipment/device all the safety equipments must be attached professionally and must be functional.
- The required personal safety equipments should be provided by the operating company.
- Safety equipments and safety devices must be checked regularly.

2.4 Safety and hazard symbols



WARNING AGAINST A HAZARD AREA

Warning information is information about the hazards that may lead to bodily injuries and/or material damages.



NOTE

Hint symbols give you valuable information and practical tips.



ELECTRICAL VOLTAGE

Warning against fatal electrical voltage.



ENVIRONMENTAL HAZARD

Protection of the environment through professional disposal of various materials and their delivery of disposal.

2.5 Safety information for using the product

All devices and assemblies have been developed and built according to the state-of-the-art technology and recognised safety-relevant rules. Nevertheless there may be hazards for the users or third parties or damages to the equipment/device or other material assets in case of improper use or handling.

The equipment/device should be used only:

- For intended use.
- In safe and faultless condition.
- Malfunctions impairing the safety should be removed by the qualified personnel immediately.

2.6 Special types of hazard

2.6.1 Electrical energy



ELECTRICAL VOLTAGE

Working with electrical components should be done only by an electrician or under the guidance and supervision of an electrician in accordance with electrical rules.

2.6.2 Hydraulic energy



HYDRAULIC SYSTEMS

Assign work at the hydraulic equipments only to personnel with special knowledge and experience in hydraulics!

2.7 Maintenance, Servicing and Troubleshooting

- Prescribed adjustment and maintenance works should be carried out according to the maintenance schedule within the stipulated time.
- Inform operating personnel before adjustment and maintenance works.
- The main switch should be switched off.
- Separate the mains plug from the network and secure against unintended operation.
- The hydraulic system must be pressureless.
- Check all the screw and fitting connections for firm position.
- After completing the work all the functions and safety equipments should be checked immediately.



CAUTION

All the works at the equipments/device should be carried out only when the equipment is at standstill.



ENVIRONMENTAL HAZARD

Various materials / fluids should be handled professionally and separated in accordance with respective regulations customary to the country and supplied for disposal.

2.8 Warranty and liability

Warranty and liability claims in case of personal injuries and material damages are excluded, if they can be attributed to one or more of the following causes:

- Unintended use of the equipment/device.
- Works carried out by unqualified persons.
- Improper transport, storage, assembly, commissioning, operation and maintenance of the equipment/device.
- Non-compliance with the information in the operating manual related to safety, storage, assembly, commissioning, operation, maintenance and setting-up of the equipment/device. Operating the equipment/device with defective safety equipments or in case of safety and protective equipments that have not been installed properly or are not functional.
- Unauthorised changes to the equipment/device.
- Unauthorised changes to the pressure conditions during pressure protection.
- Unsatisfactory monitoring of the machine parts that are subject to wear.
- Improper repairs and use of foreign parts.

3 Product description

3.1 Technical details

Modell	AX-2000 / cylindrical containers				/ conical	
	14-18 kg	20-25 kg	50 kg	180 kg	20 kg	25 kg
Containers internal Ø (mm)	255-290	290-350	350-410	560-600	260-290	306 - 335
Container height (mm)	370	470	640	850	470	
Conveyor capacity (cm ³ /min)	280					
Max. initial pressure (bar)	200					
Min. / Max. temperature C°	10 / 40					
Grease output connection	G1/4					
Voltage (V)	230 V / AC					
Power input (A)	5					
Usage medium specification	NLGI 000 bis 3					
Protection category DIN 40050	IP 55					
Demand (kW)	0.40					

3.2 Overall view AX-2000

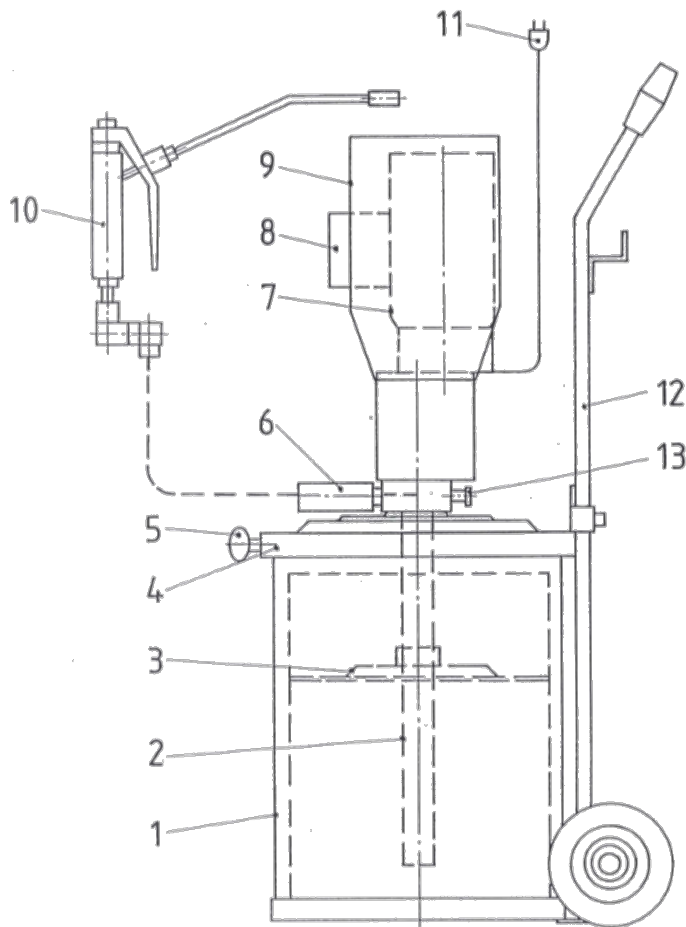

Legend

- 1) Protection tank
- 2) Suction pipe
- 3) Follower piston plate
- 4) Lid
- 5) Clamping screw
- 6) Pressure switches
- 7) Motor
- 8) switch box
- 9) Cap
- 10) Lubricating gun
- 11) Mains adapter
- 12) Drum trolley
- 13) Exhaust valve

3.3 Application

The electric grease supply system AX-2000 allows a convenient and safe lubrication wherever no compressed air is available.

3.4 Identification

The product is labelled by a product plate.



NOTE

To order spare parts and for technical support, the data on the product must be stated.



3.5 Function

The electric lubricating plant is used, above all, to lubricate devices and machines with grease in various areas of application. Depending on the design, grease containers in the range of 14 kg to 180 kg can be used.

4 Packaging and transport

The system/the device is prepared by ABNOX AG for the transport to the relevant "initial place of destination". The packaging unit must not be subjected to any additional load. The packaging and its content must be protected from any impact of humidity. The transport and storage temperature between -20°C and $+40^{\circ}\text{C}$ must be observed in any event.

4.1 Transport damage

If transport damage is discovered during goods inward inspection, the following procedure must be observed:

- Notify deliverer (freight forwarder etc.)
- Create damage record
- Inform supplier.

5 Training

- Only trained and instructed staff that have read and understood all points of the operating instructions, have mastered the individual operating modes and can implement the associated safety aspects may work on the system/device.
- Staff to be trained may only work on the system/device under the supervision of an experienced person.

6 Assembly – setting up/ installation

The device/machine must be set up or installed at the intended place of use in compliance with the below conditions.

- All legal provisions must be clarified on site and their compliance ensured.
- The ground and space conditions must be clarified before setting up the system / installing the device in order to ensure the safe operation for staff and the system/device permanently. The system/device must be assembled/installed in such a way that secure and permanent operation is ensured.
- The system/device may be set up, commissioned and/or stored by specially trained expert employees only.
- The system/device was built for rooms which are protected from the influences of weather.

7 Initial commissioning

Work free from impurities and always clean.

- Open the fat boiler and swipe the surface of the fat plane.
- Set the boiler fat into the boiler protection. Boiler protections are exclusively for cylindrical boiler up to 25 kg and conical boiler up to 20 kg.
- Providing the follower plate. If the rubber ring from the delivered follower plate doesn't have the right initial tension when assembled another rubber ring, maybe even an extra back up ring should be mounted.
- Press the follower plate into the fat until it is leaking out of the guide
- Push the pumping system carefully through the guide hole of the follower plate and fix the lid centered with the three thumb screws on the boiler protection or directly on the original one.
- Plug in the power plug and press the main switch.
- Open the vent valve until only fat emerges, close the vent valve and actuate the grease gun until no more air disappears.
- Pump is ready for operation and supplying by pressing the grease gun grease.



NOTE

All supply pumps are checked in the plant before delivery. It is therefore possible that residues of the test agent may be found in pumps.

8 Operating elements

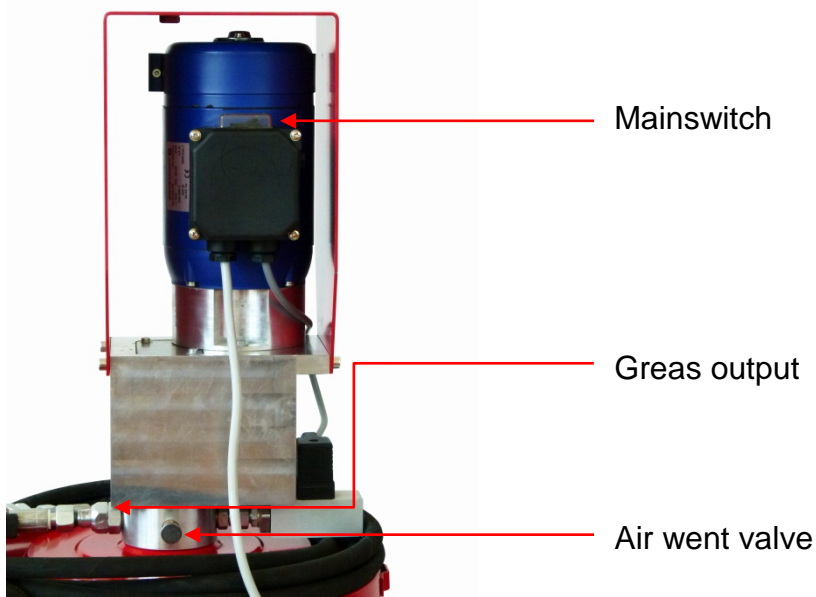

9 Finding and fixing faults



CAUTION

Risk of accidents and environmental hazards: take care not to spill any lubricant or oil.

The lubricant/oil must be disposed of in the proper manner (hazardous waste).

Fault	Possible cause	Remedy
The valve switches, but no lubricant is discharged.	Air in the grease or in the intake system.	Pump in the assembled state to press the grease. Leave open the bleeder and run system until constant grease is running.
		Control on the exhaust screw on the conveyor pump (observe operating instructions of the pump).
	Leakage.	Control of the dosage valve.
Dirt in the system:	Air pockets in the grease container Air pockets in the hoses.	Remove the supply hose on the dosage valve, allow grease to escape, then refit the hose. Restart with maximum dosage quantity.

10 Customer service/ support

ABNOX AG

Langackerstrasse 25
CH-6330 Cham
Schweiz

Tel. +41 (0) 41 780 44 55
Fax +41 (0) 41 780 44 50
E-Mail info@abnox.com
Internet www.abnox.com

11 Maintenance

This section covers maintenance of the equipment. The diagram shows when maintenance or checks need to be carried out.

11.1 Maintenance plan



CAUTION

The equipment must be switched off before any maintenance work is carried out. It must be disconnected at the mains and the plug taken out of the socket. The hydraulic system must not be pressurized.

The maintenance intervals shown relate to one-shift operation. If the equipment is used for multi-shifts it will need to be maintained more regularly.

WHEN	WHAT	HOW	WHO
Weekly	Check plant, the screws and lines for leakproofness	optical	Specialists of the operator

12 Decommissioning

12.1 Short-term interruption

In the event of a short-term interruption (over night or at the weekend), the main switch must be deactivated. The system/device is disconnected from the mains and powerless in non-activated status (control of the displays).

12.2 Long-term interruption

In the event of a longer non-use, the following points should be observed:

- The main switch must be switched off.
- The mains adapter must be disconnected from the mains.
- There must be no pressure in the system.



CAUTION

Risk of accidents and environmental hazards: take care not to spill any lubricant or oil.
The lubricant/oil must be disposed of in the proper manner (hazardous waste).

13 Spare parts



NOTE

Accessories, drawings and spare parts can be found at www.abnox.com

14 Retirement of the product

When retiring the system/device, the following points should be observed:

- The main switch must be switched off.
- The mains adapter must be disconnected from the mains.
- There must be no pressure in the system.
- The grease/oil must be removed and disposed of correctly.



CAUTION

Risks of accidents and environmental hazard: No grease/oil may be spilled.
The grease/oil must be disposed of correctly (hazardous waste).

15 Resale

These operating instructions are part of the system/device and are included in the scope of delivery in the event of a resale.

16 Optionen

Accessories for this product can be found at www.abnox.com.