

NEW!

certa
by MasoSine



The cleanest pump
you will ever need



masosine
Process Pumps

Tel: 866-777-6060
Fax: 866-777-6383

Springer Pumps, LLC

Website: www.springerpumps.com
Int'l: +001 267 404 2910

The cleanest pump you will ever need



- High suction capability to handle viscous fluids
- EHEDG Type EL - Class 1
- Uses up to 50% less power than other pump types
- Low shear and zero pulsation
- Self-draining and easy to clean for minimal downtime

Engineers in food and beverage plants are frequently faced with pumping high viscosity products ranging from frozen orange juice, deli salads and bakery produce, to cheese curd and savoury pie fillings.

Certa pumps play an important part in conveying foods safely and without degradation throughout the manufacturing and packaging process, up to 8 million centipoise (cP), and flow rates up to 41,760 litre/hour.

Certa from MasoSine sets even higher pumping standards in food processing. Certa meets the highest standards in hygiene and cleanability while improving process efficiency and minimising total cost of ownership. All this combined with the gentle product handling design of a Sine pump means Certa is the cleanest pump you will ever need.



Sine pump® advantage

Gentle pumping with virtually no pulsation – Ultra low shear pumping of whole foods, meats, dairies and concentrates with no loss to product integrity.

Superior viscous handling – Powerful suction up to 0.85 bar. Products with viscosities from 1 cP to 8 million cP can be transferred with ease.

Simplicity – Minimal downtime. One shaft, one seal and no timing gears enable easy in-place pump maintenance.

Interchangeable parts – Fully interchangeable components between pumps of the same size, reducing spares inventory.

Sine pump design



A single sinusoidal rotor creates four evenly sized chambers. As each chamber rotates it gently conveys the fluid from the inlet port to the outlet port. At the same time, the opposite chamber opens to draw in more fluid, resulting in a smooth flow with virtually no pulsation.

A gate stops fluid flow from the higher pressure outlet to the low pressure inlet.

The cleanest pump you will ever need

Cleaner than any lobe or circumferential piston pump

- EHEDG Type EL - Class 1
- Reduce your CIP cycle and the amount of cleaning agents required
- All contact parts FDA and EC1935 compliant
- Reduce chemical and water use and wastewater for disposal
- Modular seal system options:
 - Single mechanical seal
 - Single mechanical seal with flush
 - Double mechanical seal

Virtually pulsation free

- Smooth product flow with no need for ancillary dampeners, ensuring product quality
- Improves flow meter accuracy and heat exchanger efficiency

Lowest cost of ownership

- Extremely simple maintenance performed in-place by a line operative
- Patented design allows bi-directional running to pump duty fluid back to source
- One shaft, one rotor, one seal and no complex timing gears

Low shear handling for particulates and soft solids

- Improves batch consistency and final product quality
- Virtually eliminates wastage of raw ingredients
- Low shear action prevents aeration and foaming during product transfer

Energy efficient

- Requires up to 50% less power than lobe or circumferential piston pumps
- Greatly reduced electricity use means reduced carbon footprint
- Higher efficiency at high viscosity increases energy savings in your most difficult applications.

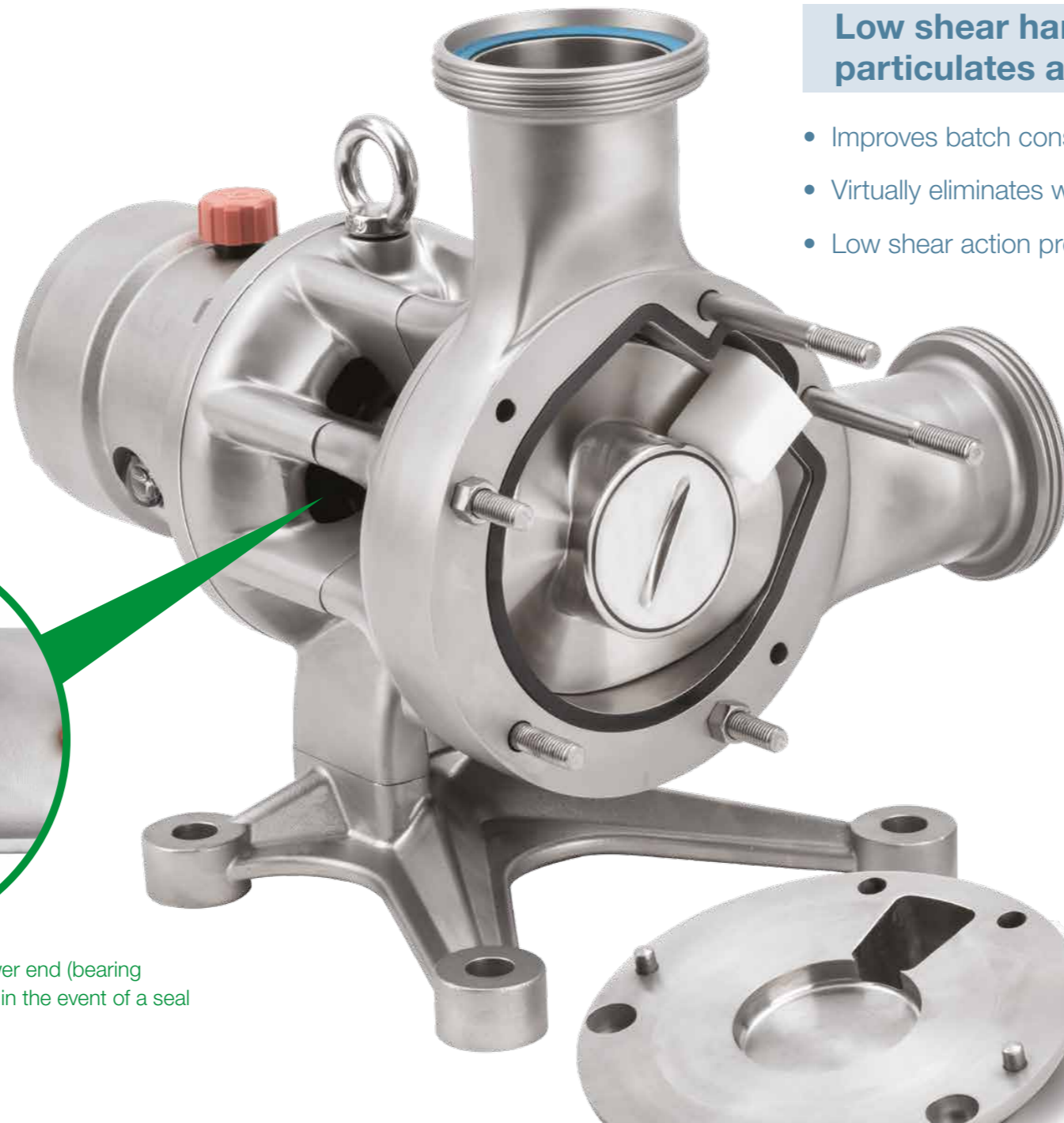

A space between wet end (pumphead) and power end (bearing housing) of the pump, ensures fluid drains away in the event of a seal failure and eliminates the risk of contamination.



Sustainability curves

MasoSine Energy Efficiency (Mee) curves demonstrate how the sine principle requires less power to operate in viscous applications. The curves demonstrate clearly how MasoSine pumps help organisations achieve greater sustainability.

Applications



◀ Beverages

Handling fruit juice concentrates with high viscosity can make pumping slow and prone to cavitation. This is especially true if the temperature drops below 0C, at which point viscosity will make a step increase. When viscosity increases, the maximum running speed of a lobe or circumferential piston pump needs to be reduced considerably to avoid cavitation, so reducing the achievable flow rate. Additionally, power consumption drastically increases as the rotors cut through the thicker fluid.

With Certa, changing to a higher viscosity product has negligible impact on the flow rate or power required. For example, increasing viscosity from 20,000 cP to 200,000 cP nominally increases the viscous horsepower (VHP) by around 0.1 to 0.3 VHP (0.22 kW).

Sine pumps also have a lower net positive suction head requirement (NPSHR) to minimise potential for cavitation with thick fluids.



◀ Dairy

In the cost conscious dairy sector, finding ways to reduce cleaning costs is a major challenge and one which the Certa pump easily solves.

The most common method for cleaning both pumps and pipework systems employed in the dairy industry, is CIP or clean in place, using large volumes of water and a cleaning agent which is dispersed through the entire fluid handling system. Chemicals such as sodium hydroxide, nitric acid and phosphoric acid at concentrations below 1%, are diluted in distilled water for CIP.

Pumps are some of the most difficult equipment to clean via CIP. CIP cycles often take between 20 and 40 minutes to perform, depending on the system employed. That time is non-productive and the manufacturing/processing stops while CIP is performed. The simplicity of the new Certa pump reduces your CIP cycle and the amount of cleaning agents required.



Bakery ▶

With demand for fresh bakery products rising globally, bakers are seeking improvements in processing everything from dough and batter, to confectionery fillings and frostings. Competition is fierce and product quality becomes a vital element of sales success.

Viscosities can register in the thousands, or even millions of centipoise, often requiring costly oversizing of lobe and circumferential piston pumps to handle the high viscosity and reduce shear. With superior viscosity performance, Certa pumps play an important part in conveying the ingredients and mixes without degradation throughout the manufacturing and packaging process. Certa's gentle product handling capabilities and low shear improve product quality and appearance.



Handling particulates and soft solids ▶

When inclusions such as soft fruit, diced vegetables, cooked pulses or meat are present, the Certa pump handles these soft solids without blockages and without causing damage to the ingredients. In testing, Certa pumps showed 50% less product degradation than a similar sized lobe pump.



Options and accessories

Connection ports

Certa pumps are available with all standard ports to match your application including DIN, TC, RJT and SMS. Customised options are available upon request.



Port orientations

Pumps can be configured with ports in a range of orientations to meet installation requirements, including a self-draining orientation.



Accessories

A static and dynamic flush system is available to flush the area behind the seal system, at low pressure, to prevent product from hardening and damaging the seal system. This is even possible with a single mechanical seal.

A jacketing system is available to allow pumps to be heated to the optimal temperature for your process, for example when pumping chocolate.

Priming devices for dry priming are also available.



Service and support



Service

We believe in providing the highest standard of service to our customers, at every level. We work with them to understand their applications and pressures affecting their business, and provide solutions that are specifically matched to their requirements.

Support

Customer support is provided through a network of sine pump specialists and technical support teams. This ensures our customers always benefit from local knowledge and MasoSine pump expertise. No matter where your business operates, MasoSine is never far away.

Genuine spares

MasoSine's approved parts policy means only the highest quality materials are used in the manufacture of our pumps. This gives our customers confidence that our pumps will not let them down.

Essential spare parts can be despatched on the day the order is received. Standard pumps can be despatched within 24 hours.



Technical data

Performance curves

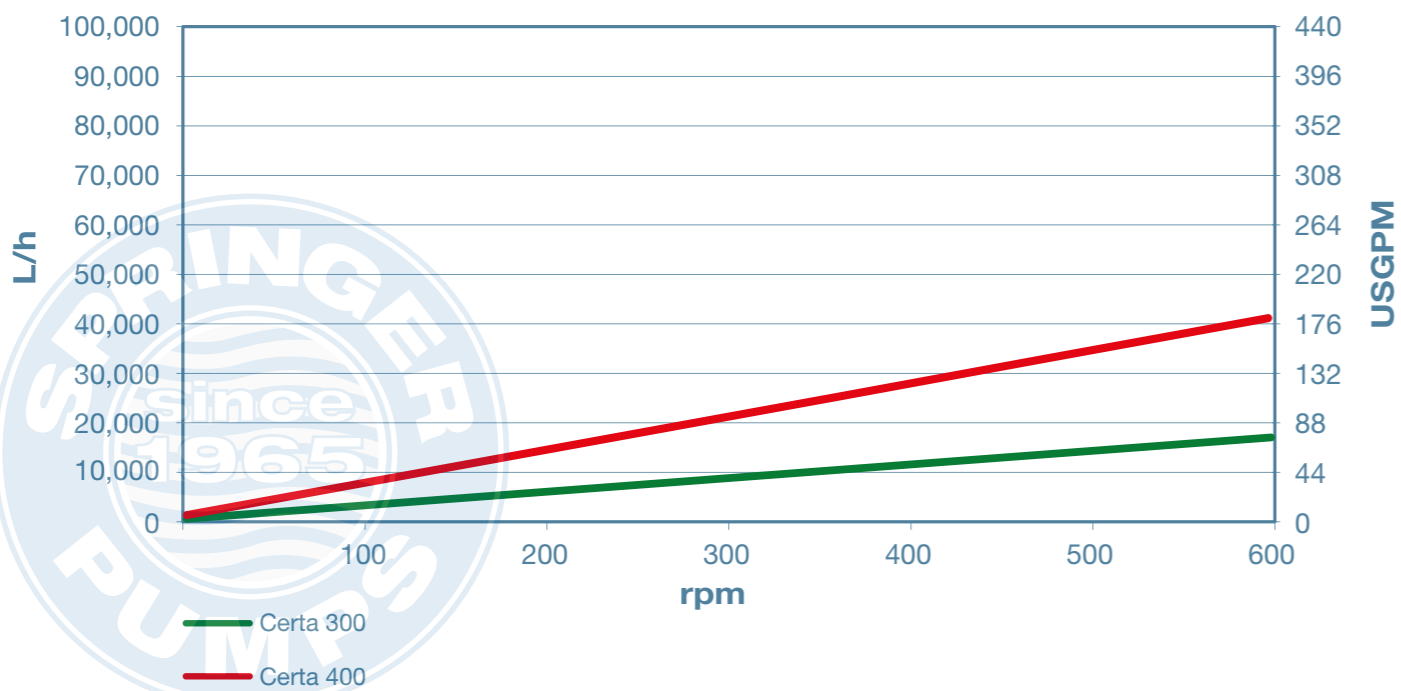
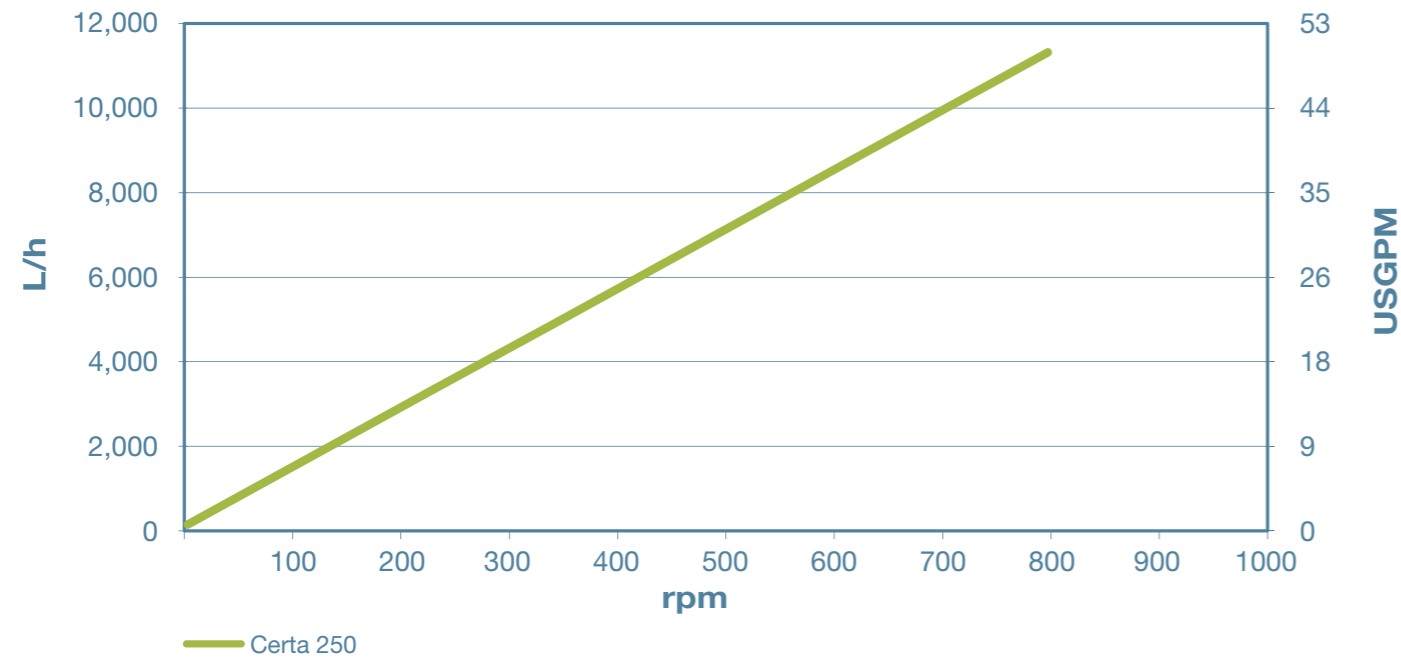

Dimensions

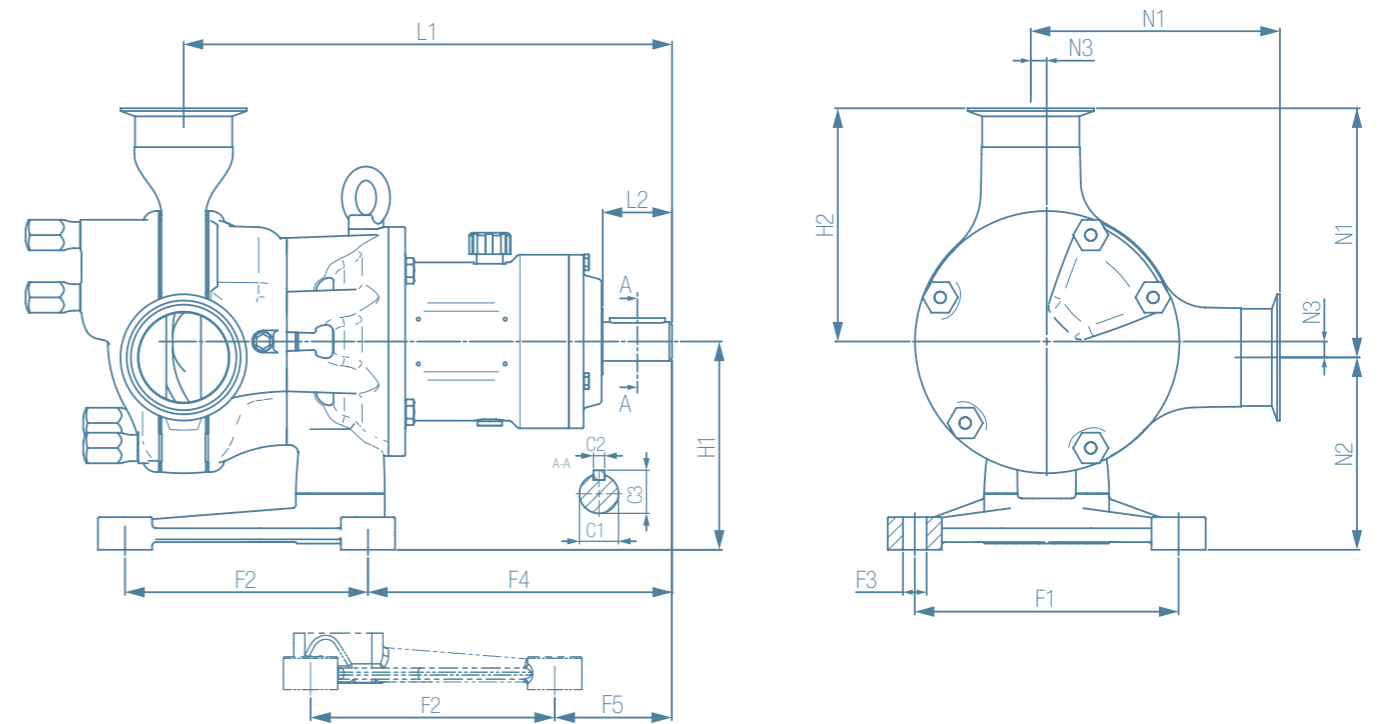

Model	Nozzles			Foot					Length		Height		Coupling		
	N1	N2	N3	F1	F2	F3	F4	F5	L1	L2	H1	H2	C1	C2	C3
	mm	mm	mm	mm	mm	mm	mm	mm	mm	mm	mm	mm	mm	mm	mm
Certa 250	191.5	138.5	11.5	190	175	Ø17	219	84	352	50	150	180	Ø28	8	31
Certa 300	237.5	152.5	17.5	250	215	Ø20	285	154	455.5	80	170	220	Ø50	14	53.5
Certa 400	323.5	169	31	266.5	254	Ø21	301	169	513.5	77	200	292.5	Ø50	14	53.5

Technical Data

Model	Maximum particle size	Volume per revolution	Speed	Maximum flow	Maximum pressure	Maximum temperature
	mm	litre	rpm	l/h	bar	C
Certa 250	22	0.24	800	11,520	15	100
Certa 300	30	0.50	600	18,000	15	100
Certa 400	48	1.16	600	41,760	15	100

**WATSON
MARLOW**

Fluid Technology Group

A Spirax-Sarco Engineering Company

Watson-Marlow Fluid Technology Group has nine world-class factories supported by direct sales operations in 30 countries and distributors in more than 50 countries. For contact details visit our website:

www.wmftg.com

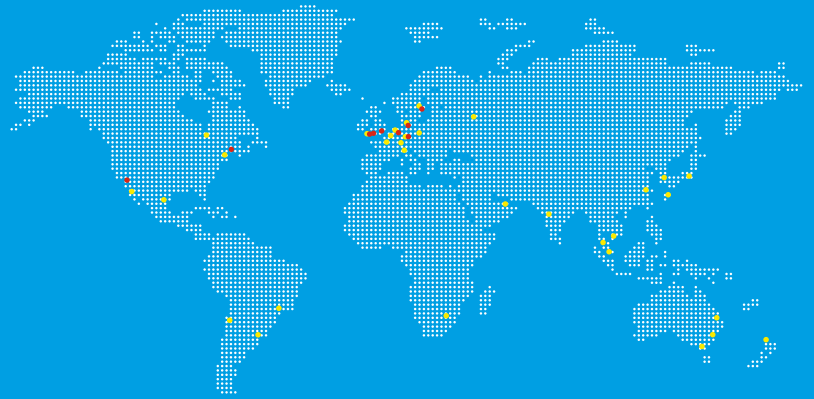

Watson-Marlow

Alitea

Bredel

Flexicon

MasoSine

BioPure

ASEPCO

FlowSmart



Watson-Marlow online

Our engineers around the world can help you choose the perfect pump and tubing for your needs.

More information? Our brochures are on our website - www.wmftg.com



Watson-Marlow... Innovation in Full Flow

Tel: +44 (0) 1326 370370
info@wmftg.co.uk

Watson-Marlow Fluid Technology Group
Falmouth, Cornwall, TR11 4RU, UK
www.wmftg.co.uk

Disclaimer: The information contained in this document is believed to be correct but Watson-Marlow Limited accepts no liability for any errors it contains and reserves the right to alter specifications without notice. It is the users responsibility to ensure product suitability for use within their application. Watson-Marlow, MasoSine and Sine are registered trademarks of Watson-Marlow Limited. Certa and mee are trademarks of Watson-Marlow Limited.

Tel: 866-777-6060
Fax: 866-777-6383

Springer Pumps, LLC

Website: www.springerpumps.com
Int'l: +001 267 404 2910