

➤➤ HOLLOW CONE NOZZLES

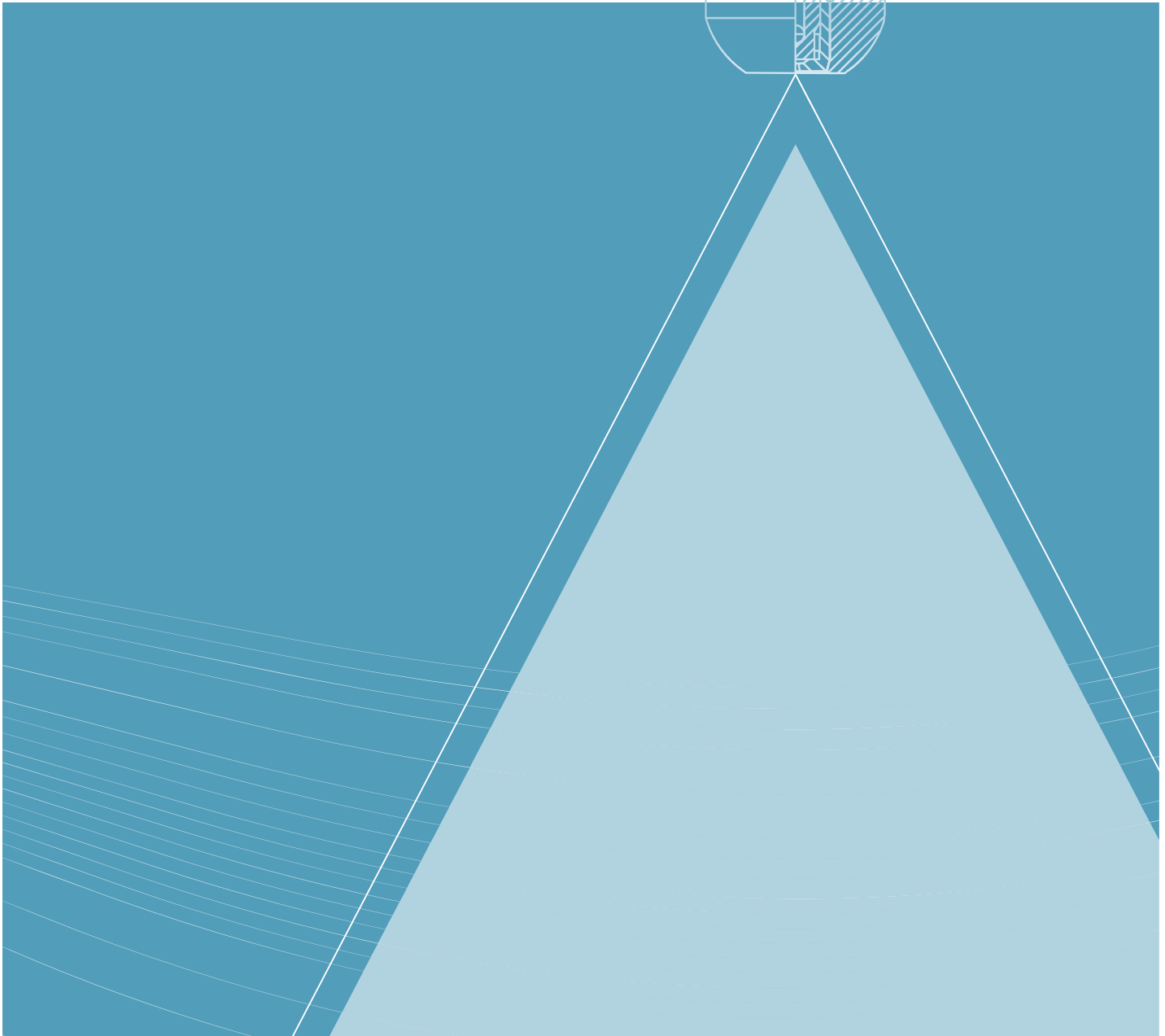

» HOLLOW CONE NOZZLES OVERVIEW OF TYPES

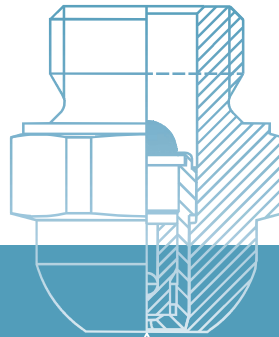
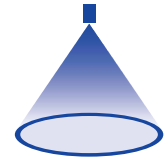

Hollow cone nozzles are used wherever fine droplets are required. A distinction is made between axial-flow hollow cone nozzles and tangential-flow hollow cone nozzles. Axial-flow hollow cone nozzles are mainly used for cooling, humidification and disinfecting, whilst tangential-flow hollow cone nozzles are traditionally used for humidification of air, dust control, sprinkling and foaming.

Axial-flow hollow cone nozzles



- High and controlled degree of atomization due to integrated swirl insert
- Narrow droplet spectrum
- Uniform atomization
- Large droplet surface area for mass transfer processes

Tangential-flow hollow cone nozzles











- Liquid rotation without swirl insert
- Maximum free passage making less susceptible to clogging
- Large free cross sections
- Operational reliability
- Coarse droplets that are larger than axial-flow hollow cone nozzles









Hollow cone
nozzles

HOLLOW CONE NOZZLES OVERVIEW OF SERIES



		Axial-flow hollow cone nozzles			
					
Series		220	226	214/216	2TR
Information on page		66	67	68	69
 Flow rate at p = 2 bar	Very low < 0.5 l/min	● (at p = 5 bar)	● (at p = 5 bar)	● (at p = 5 bar)	● (at p = 5 bar)
	Low 0.5 l/min–2.0 l/min			● (at p = 5 bar)	● (at p = 5 bar)
	Medium 2.0 l/min–10.0 l/min			● (at p = 5 bar)	
	High 10.0 l/min–50.0 l/min			● (at p = 5 bar)	
	Very high > 50.0 l/min				
 Spray angle	Small 45°				
	Medium 55°–95°	●	●	●	●
	Large 130°				
 Nozzle material	Stainless steel	●	●	●	
	Brass			●	
	Plastic				●
 Nozzle connection		1/4 BSPP	Assembly with retaining nut 3/8 BSPP	1/8 BSPP 3/8 BSPP	Assembly with retaining nut 3/8 BSPP

Tangential-flow hollow cone nozzles

					
302	302 with bayonet quick-release system	308	304/306/307	350	373 Ramp Bottom
70/71	66	74	75	76	77
•	•				
•	•	•		•	
•		•	•	•	
•			•		
					•
	•				
•	•	•	•		•
•	•		•	•	
•			•		•
•		•	•		
•	•			•	
3/8 BSPP	Assembly with bayonet quick-release system	3/8 BSPP	1/2 BSPP 3/4 BSPP	3/8 BSPP quick-release system	1 BSPP 1 1/4 BSPP 1 1/2 BSPP

➤ Axial-flow hollow cone nozzles Series 220

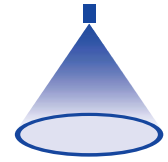

Features:

- Extremely fine, fog-like atomization

Applications:

- Humidification
- Cooling
- Disinfection
- Chemical engineering
- Adiabatic cooling

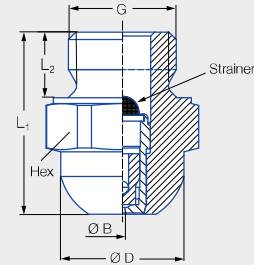

Series 220

Code	G	Dimensions [mm]				Weight [g]
		L ₁	L ₂	Ø D	Hex	
AC	1/4 BSPP	22.0	8.0	15.0	17	27.0

Spray angle	Ordering no.				Bore diameter B [mm]	Narrowest free cross section Ø [mm]	Strainer insert mesh size [mm]	V̇ water [l/min]								Spray diameter D [mm] (at p = 5 bar)
	Type	Mat. no.		Code				p [bar]								
		1Y	11					2.0	3.0	5.0	7.0	10.0	20.0	50.0	100.0	
60°	220.004	●	●	AC	0.10	0.10	0.04	–	–	0.013	0.015	0.018	0.026	0.041	0.058	120
								–	0.015	0.019	0.022	0.027	0.038	0.060	0.085	140
								0.017	0.021	0.027	0.032	0.038	0.054	0.085	0.121	160
80°	220.085	●	●	AC	0.25	0.25	0.10	0.025	0.031	0.040	0.047	0.057	0.080	0.126	0.179	190
								0.039	0.048	0.062	0.073	0.088	0.124	0.196	0.277	230
								0.052	0.064	0.082	0.097	0.116	0.164	0.259	0.367	250
								0.065	0.080	0.103	0.122	0.146	0.206	0.326	0.461	260
								0.082	0.101	0.130	0.154	0.184	0.260	0.411	0.581	270
								0.106	0.130	0.168	0.199	0.238	0.336	0.531	0.751	280
								0.165	0.202	0.261	0.309	0.369	0.522	0.825	1.167	290
0.247	0.302	0.390	0.461	0.552	0.780	1.233	1.744	300								

Mat. no.	Housing	Nozzle insert	Strainer
1Y	Stainless steel 316L	Stainless steel 316L	Stainless steel 316L
11	Stainless steel 430F	Stainless steel 430F	Stainless steel 316L

The supplied and integrated strainer insert prevents clogging of the nozzle, thereby ensuring a long service life.

Conversion formula for this series: $\dot{V}_2 = \dot{V}_1 \cdot \sqrt{\frac{p_2}{p_1}}$

Ordering Type + Material no. + Code = Ordering no.
example: 220.004 + 1Y + AC = 220.004.1Y.AC



Assembly accessories can be found in Chapter 9 "Accessories".

➤ Axial-flow hollow cone nozzles Series 226

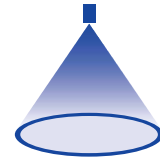

Features:

- Extremely fine, fog-like atomization
- Assembly with retaining nut

Applications:

- Humidification
- Cooling
- Disinfection
- Chemical engineering
- Adiabatic cooling

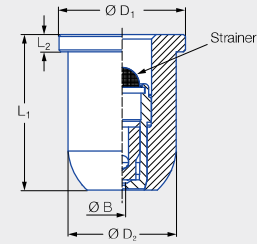

Series 226

Code	Dimensions [mm]				Weight [g]
	L ₁	L ₂	Ø D ₁	Ø D ₂	
Assembly with retaining nut 3/8 BSPP	18.00	2.00	14.80	12.65	20.00

Spray angle	Ordering no.		Bore diameter B [mm]	Narrowest free cross section Ø [mm]	Strainer insert mesh size [mm]	V̇ water [l/min]								Spray diameter D [mm] (at p = 5 bar)
	Type	Mat. no.				p [bar]								
		16				2.0	3.0	5.0	7.0	10.0	20.0	50.0	100.0	
		Stainless steel 303												H = 250 [mm]
60°	226.004	●	0.10	0.10	0.04	–	–	0.013	0.015	0.018	0.026	0.041	0.058	120
	226.014	●	0.15	0.15	0.04	–	0.015	0.019	0.022	0.027	0.038	0.060	0.085	140
	226.054	●	0.20	0.15	0.04	0.017	0.021	0.027	0.032	0.038	0.054	0.085	0.121	160
80°	226.085	●	0.25	0.25	0.10	0.025	0.031	0.040	0.047	0.057	0.080	0.126	0.179	190
	226.125	●	0.35	0.35	0.10	0.039	0.048	0.062	0.073	0.088	0.124	0.196	0.277	230
	226.145	●	0.40	0.40	0.10	0.052	0.064	0.082	0.097	0.116	0.164	0.259	0.367	250
	226.165	●	0.45	0.45	0.10	0.065	0.080	0.103	0.122	0.146	0.206	0.326	0.461	260
	226.185	●	0.55	0.35	0.20	0.082	0.101	0.130	0.154	0.184	0.260	0.411	0.581	270
	226.205	●	0.60	0.35	0.20	0.106	0.130	0.168	0.199	0.238	0.336	0.531	0.751	280
	226.245	●	0.70	0.50	0.20	0.165	0.202	0.261	0.309	0.369	0.522	0.825	1.167	290
	226.285	●	0.90	0.55	0.20	0.247	0.302	0.390	0.461	0.552	0.780	1.233	1.744	300

Mat. no.	Housing	Nozzle insert	Strainer
16	Stainless steel 303	Stainless steel 430F	Stainless steel 316L

The supplied and integrated strainer insert prevents clogging of the nozzle, thereby ensuring a long service life.

Conversion formula for this series: $\dot{V}_2 = \dot{V}_1 \cdot \sqrt{\frac{p_2}{p_1}}$

Ordering Type + Material no. = Ordering no.
example: 226.004 + 16 = 226.004.16



Assembly accessories can be found in Chapter 9 "Accessories".

➤ Axial-flow hollow cone nozzles Series 214/216



Features:

- Fine, uniform atomization

Applications:

- Cooling
- Gas washing
- Dust control
- Sprinkling
- Adiabatic cooling

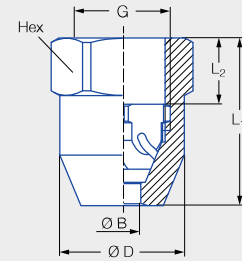

Series 214/216

Series	G	Dimensions [mm]				Weight [kg] (Brass)
		L ₁	L ₂	Ø D	Hex	
214	1/8 BSPP	18.0	6.0	16.0	17	27.0
216	3/8 BSPP	29.0	12.0	21.3	22	60.0

Spray angle	Ordering no.			Bore diameter B [mm]	Narrowest free cross section Ø [mm]	ṽ water [l/min]							Spray diameter D [mm] (at p = 5 bar)
	Type	Mat. no.				p [bar]							
		Stainless steel 316Ti	Brass			0.5	1.0	2.0	3.0	5.0	10.0	20.0	
60°	214.184	●	●	0.50	0.50	–	–	0.08	0.10	0.13	0.18	0.25	120
	216.324	●	●	1.00	1.00	–	0.28	0.40	0.49	0.63	0.89	1.26	190
	216.364	●	●	1.40	1.40	–	0.45	0.63	0.77	1.00	1.41	1.99	220
	216.404	●	●	2.00	2.00	–	0.71	1.00	1.22	1.58	2.24	3.16	240
80°	214.245	●	●	1.00	0.50	–	–	0.16	0.20	0.25	0.36	0.51	240
	214.305	●	●	1.80	0.50	–	0.23	0.32	0.39	0.51	0.72	1.01	320
90°	216.496	●	●	3.00	2.00	–	1.20	1.70	2.08	2.69	3.80	5.38	430
	216.566	●	●	4.00	2.00	–	1.77	2.50	3.06	3.95	5.59	7.91	430
	216.646	●	●	3.50	2.00	2.00	2.83	4.00	4.90	6.32	8.94	12.65	440
	216.686	●	●	4.00	2.00	2.50	3.54	5.00	6.12	7.91	11.18	15.81	450
	216.726	●	●	5.00	2.00	3.15	4.45	6.30	7.72	9.96	14.09	19.92	460
	216.776	●	●	6.00	2.00	4.30	6.00	8.50	10.40	13.40	19.00	26.90	470

Conversion formula for this series: $\dot{V}_2 = \dot{V}_1 \cdot \sqrt{\frac{p_2}{p_1}}$

Ordering Type + Material no. = Ordering no.
example: 214.184 + 17 = 214.184.17

Assembly accessories can be found in Chapter 9 "Accessories".

➤ Axial-flow hollow cone nozzles Series 2TR

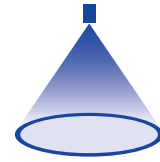

Features:

- Fine, uniform atomization
- Assembly with retaining nut

Applications:

- Sprinkling
- Adiabatic cooling
- Cooling
- Humidification of air

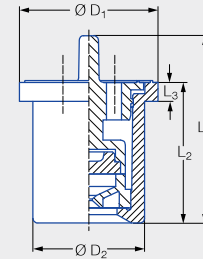

Series 2TR

Hollow cone
nozzles

Code	Dimensions [mm]					Weight [kg]
	L ₁	L ₂	L ₃	Ø D ₁	Ø D ₂	
Assembly with retaining nut 3/8 BSPF	20.0	15.0	2.0	14.8	11.9	3.0

Spray angle	Ordering no.		Color	Bore diameter B [mm]	Narrowest free cross section Ø [mm]	V̇ water [l/min]						Spray diameter D [mm] (at p = 5 bar)
	Type	Mat. no.				p [bar]						
		C8				Housing: POM Insert: Ceramic	1.0	2.0	3.0	5.0	7.0	10.0
80°	2TR.245	●	Purple	0.65	0.55	–	0.16	0.20	0.25	0.30	0.36	220
	2TR.275	●	Black	0.80	0.70	0.16	0.22	0.27	0.35	0.41	0.49	260
	2TR.305	●	Orange	0.90	0.80	0.23	0.32	0.39	0.51	0.60	0.72	320
	2TR.345	●	Green	1.10	0.90	0.34	0.48	0.59	0.76	0.90	1.07	420
	2TR.365	●	Yellow	1.40	0.95	0.46	0.65	0.80	1.03	1.22	1.45	490
	2TR.405	●	Blue	1.70	1.10	0.69	0.97	1.19	1.53	1.81	2.17	530
	2TR.445	●	Red	2.00	1.20	0.89	1.26	1.55	2.02	2.37	2.83	550
2TR.485	●	Brown	2.20	1.30	1.11	1.57	1.94	2.50	2.96	3.54	560	

Assembly example



Conversion formula for this series: $\dot{V}_2 = \dot{V}_1 \cdot \sqrt{\frac{\rho_2}{\rho_1}}$

Ordering Type + Material no. = Ordering no.
example: 2TR.245 + C8 = 2TR.245.C8

Assembly accessories can be found in Chapter 9 "Accessories".

» Tangential-flow hollow cone nozzles, stainless steel/brass version

Series 302



Features:

- Uniform atomization
- Non-clogging nozzle without swirl insert

Applications:

- Humidification of air
- Dust control
- Sprinkling
- Foam control
- Adiabatic cooling



Series 302

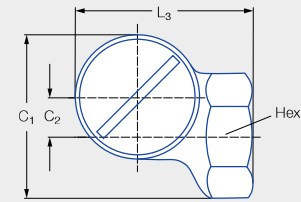
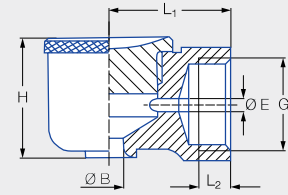

G	Dimensions [mm]							Weight [g] (Brass)
	C ₁	C ₂	H	L ₁	L ₂	L ₃	Hex	
3/8 BSPP	34.0	8.0	23.0	23.0	6.5	36.0	22	90.0

Spray angle	Ordering no.		Bore diameter B [mm]	Narrowest free cross section Ø [mm]	V̇ water [l/min]							Spray diameter D [mm] (at p = 2 bar)		
	Type	Mat. no.			p [bar]							H = 250 [mm]	H = 500 [mm]	
		1Y			30	0.5	1.0	2.0	3.0	5.0	7.0			10.0
		Stainless steel 316L			Brass									
60°	302.364		●	1.50	1.50	0.32	0.45	0.63	0.77	1.00	1.18	1.41	280	420
	302.464	●	●	2.00	2.00	0.70	0.99	1.40	1.71	2.21	2.62	3.13	280	460
80°	302.545	●	●	4.90	2.30	1.12	1.58	2.24	2.74	3.54	4.19	5.01	360	660
90°	302.606	●	●	4.60	4.00	1.58	2.23	3.15	3.86	4.98	5.89	7.04	470	810
130°	302.368	●	●	3.00	1.00	0.32	0.45	0.63	0.77	1.00	1.18	1.41	660	1,080
	302.468	●	●	5.00	1.70	0.70	0.99	1.40	1.71	2.21	2.62	3.13	810	1,370
	302.548		●	5.00	2.50	1.12	1.58	2.24	2.74	3.54	4.19	5.01	960	1,640
	302.608	●	●	5.00	3.50	1.58	2.23	3.15	3.86	4.98	5.89	7.04	1,060	1,800
	302.668	●	●	7.50	3.60	2.25	3.18	4.50	5.51	7.12	8.42	10.06	1,120	1,950
	302.748	●	●	7.50	4.80	3.55	5.02	7.10	8.70	11.23	13.28	15.88	1,160	2,150

Conversion formula for this series: $\dot{V}_2 = \dot{V}_1 \cdot \sqrt{\frac{p_2}{p_1}}$

Ordering Type + Material no. = Ordering no.
example: 302.364 + 30 = 302.364.30

 Assembly accessories can be found in Chapter 9 "Accessories".

➤ Tangential-flow hollow cone nozzles, plastic version

Series 302

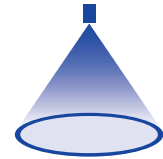

Features:

- Uniform atomization
- Non-clogging nozzle without swirl insert

Applications:

- Humidification of air
- Dust control
- Sprinkling
- Foam control
- Adiabatic cooling



Series 302

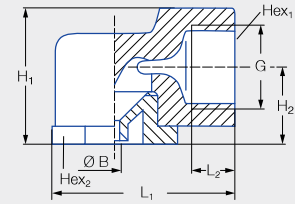

Type 302.32x-302.48x

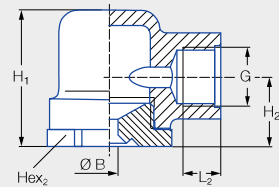

Type 302.52x-302.96x

Type	G	Dimensions [mm]						Weight [g]	ρ_{max} [bar]
		H ₁	H ₂	L ₁	L ₂	Hex ₁	Hex ₂		
302.32x-302.48x	3/8 BSPP	27.5	16.5	43.5	10.0	22	22	13.0	5.0
302.52x-302.96x	3/8 BSPP	34.0	18.5	37.0	10.0	22	22	18.0	5.0

Spray angle	Ordering no.			Bore diameter B [mm]	Narrowest free cross section Ø [mm]	V̇ water [l/min]					Spray diameter D [mm] (at p = 2 bar)		
	Type	Mat. no.				p [bar]					H = 250 [mm]	H = 500 [mm]	
		51	5E			53	0.5	1.0	2.0	3.0			5.0
		PA	PVDF			PP							
60°	302.364	●		●	1.30	1.30	0.32	0.45	0.63	0.77	1.00	320	600
	302.464	●		●	1.95	1.95	0.70	0.99	1.40	1.71	2.21	330	620
90°	302.326	●	●		1.05	1.05	0.20	0.28	0.40	0.49	0.63	470	770
	302.366	●	●		1.30	1.30	0.32	0.45	0.63	0.77	1.00	480	790
	302.406	●	●	●	1.55	1.55	0.50	0.71	1.00	1.22	1.58	490	810
	302.486	●		●	2.10	2.10	0.80	1.13	1.60	1.96	2.53	510	850
	302.526	●		●	5.00	2.00	1.00	1.41	2.00	2.45	3.16	520	870
	302.566	●		●	5.00	2.40	1.25	1.77	2.50	3.06	3.95	520	900
	302.606	●		●	5.00	3.20	1.58	2.23	3.15	3.86	4.98	530	940
	302.686	●			7.50	3.40	2.50	3.54	5.00	6.12	7.91	540	1,010
	302.766	●			9.00	4.30	4.00	5.66	8.00	9.80	12.65	540	1,040
	302.846	●		●	11.00	5.20	6.25	8.84	12.50	15.31	19.67	540	1,050
302.886	●	●	●	11.00	6.40	8.00	11.31	16.00	19.60	25.30	540	1,050	
302.966	●			11.00	8.60	12.50	17.68	25.00	30.62	39.53	540	1,050	





Spray angle	Ordering no.			Bore diameter B [mm]	Narrowest free cross section Ø [mm]	V̇ water [l/min]					Spray diameter D [mm] (at p = 2 bar)		
	Type	Mat. no.				p [bar]					H = 250 [mm]	H = 500 [mm]	
		51	5E			53	0.5	1.0	2.0	3.0			5.0
	PA	PVDF	PP										
130°	302.328	●	●		1.35	0.80	0.20	0.28	0.40	0.49	0.63	640	930
	302.368	●	●		1.85	1.10	0.32	0.45	0.63	0.77	1.00	660	1,010
	302.408	●	●		3.65	1.30	0.50	0.71	1.00	1.22	1.58	680	1,110
	302.488	●		●	5.20	1.60	0.80	1.13	1.60	1.96	2.53	720	1,250
	302.528	●			5.00	2.00	1.00	1.41	2.00	2.45	3.16	750	1,330
	302.568	●			5.00	2.40	1.25	1.77	2.50	3.06	3.95	780	1,410
	302.608	●	●	●	5.00	3.20	1.58	2.23	3.15	3.86	4.98	820	1,500
	302.648	●			7.50	3.00	2.00	2.83	4.00	4.90	6.32	860	1,590
	302.688	●			7.50	3.40	2.50	3.54	5.00	6.12	7.91	900	1,650
	302.728	●			7.50	4.10	3.15	4.45	6.30	7.72	9.96	920	1,700
	302.768	●			9.00	4.30	4.00	5.66	8.00	9.80	12.65	940	1,730
	302.848	●			11.00	5.20	6.25	8.84	12.50	15.31	19.76	960	1,760
	302.888	●		●	11.00	6.40	8.00	11.31	16.00	19.60	25.30	970	1,780
302.968	●	●		11.00	8.60	12.50	17.68	25.00	30.62	39.53	1000	1,800	

Conversion formula for this series: $\dot{V}_2 = \dot{V}_1 \cdot \sqrt{\frac{p_2}{p_1}}$

Ordering Type + Material no. = Ordering no.
 example: 302.328 + 5E = 302.328.5E

 Assembly accessories can be found in Chapter 9 "Accessories".

➤ Tangential-flow hollow cone nozzles, plastic version with bayonet quick-release system Series 302

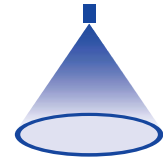

Features:

- Uniform atomization
- Non-clogging nozzle without swirl insert
- Quick and secure assembly thanks to bayonet quick-release system
- Setting of spray direction



Series 302

Applications:

- Humidification of air
- Dust control
- Sprinkling
- Foam control
- Adiabatic cooling

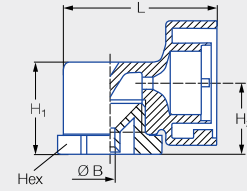

Type 302.32x-302.54x

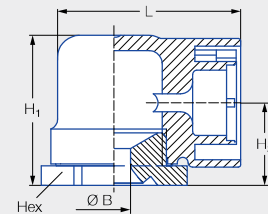

Type 302.606.51.KB

Type	Code	Dimensions [mm]				Weight [g]	p _{max} [bar]
		H ₁	H ₂	L	Hex		
302.32x-302.54x	KB	21.8	16.8	36.0	22	12.0	5.0
302.606.51.KB	KB	34.0	19.0	42.0	30	19.0	5.0

Spray angle	Ordering no.			Bore diameter B [mm]	Narrowest free cross section Ø [mm]	V̇ water [l/min]					Spray diameter D [mm] (at p = 2 bar)		
	Type	Mat. no.				Code	p [bar]					 H = 250 [mm] H = 500 [mm]	
		51	56				0.5	1.0	2.0	3.0	5.0		
45°	302.503	●		KB	2.05	2.05	0.90	1.27	1.80	2.20	2.85	210	430
60°	302.464		●	KB	1.95	1.95	0.70	0.99	1.40	1.71	2.21	290	540
80°	302.545		●	KB	2.30	2.30	1.12	1.58	2.24	2.74	3.54	450	810
90°	302.326	●	●	KB	1.05	1.05	0.20	0.28	0.40	0.49	0.63	400	720
	302.406	●	●	KB	1.55	1.55	0.50	0.71	1.00	1.22	1.58	400	740
	302.486	●		KB	2.10	2.10	0.80	1.13	1.60	1.96	2.53	450	800
	302.606	●		KB	5.00	3.20	1.58	2.23	3.15	3.86	4.98	530	1,000
130°	302.686		●	KB	7.50	3.40	2.50	3.54	5.00	6.13	7.91	540	1,010
	302.368		●	KB	1.30	1.30	0.32	0.45	0.63	0.77	1.00	660	1,100
	302.408	●	●	KB	2.00	2.00	0.50	0.71	1.00	1.22	1.58	680	1,200
	302.468	●		KB	2.40	2.40	0.70	0.99	1.40	1.71	2.21	680	1,250
	302.488	●		KB	2.75	2.75	0.80	1.13	1.60	1.96	2.53	720	1,300

Conversion formula for this series: $\dot{V}_2 = \dot{V}_1 \cdot \sqrt{\frac{p_2}{p_1}}$

Ordering Type + Material no. + Code = Ordering no.
example: 302.503 + 51 + KB = 302.503.51.KB

 Assembly accessories can be found in Chapter 9 "Accessories".

» Tangential-flow hollow cone nozzles Series 308

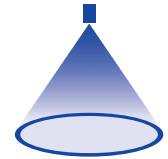

Features:

- Uniform atomization
- Non-clogging nozzle without swirl insert
- Adjustable flow rate

Applications:

- Humidification of air in air washers
- Dust control
- Spraying onto filters
- Foam control
- Cooling



Series 308

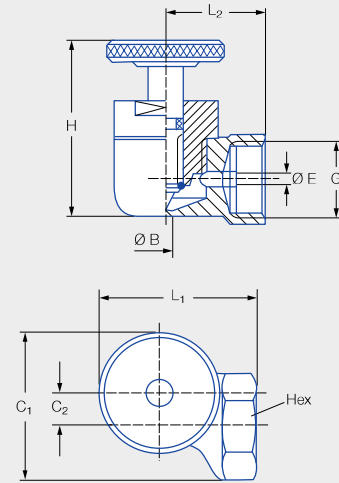

G	Dimensions [mm]						Weight [g]
	C ₁	C ₂	H	L ₁	L ₂	Hex	
3/8 BSPP	34.0	8.0	40.0	36.0	23.0	22	150.0

Spray angle	Ordering no.		Bore diameter B [mm]	Narrowest free cross section Ø [mm]	V _{max} water [l/min]						Spray diameter D [mm] (at p = 2 bar)	
	Type	Mat. no.			p [bar]						 H = 250 [mm] H = 500 [mm]	
		30			0.3	0.5	1.0	2.0	5.0	10.0		
90°	308.466	●	2.00	2.00	0.54	0.70	1.00	1.40	2.21	3.13	440	830
	308.606	●	4.00	4.00	1.22	1.58	2.23	3.15	4.98	7.04	460	850

Conversion formula for this series: $\dot{V}_2 = \dot{V}_1 \cdot \sqrt{\frac{p_2}{p_1}}$

Ordering Type + Material no. = Ordering no.
example: 308.466 + 30 = 308.466.30

 Assembly accessories can be found in Chapter 9 "Accessories".

➤ Tangential-flow hollow cone nozzles

Series 304/306/307



Features:

- Uniform atomization
- Non-clogging nozzle without swirl insert

Applications:

- Storage tank cooling
- Foam control
- Dust control
- Surface spraying
- Absorption



Series 304/306/307

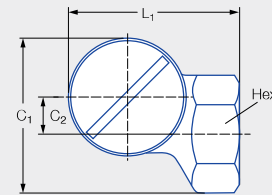
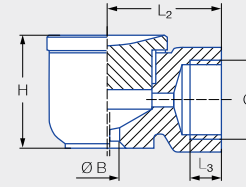

Series	G	Dimensions [mm]							Weight [g] (Brass)
		C ₁	C ₂	H	L ₁	L ₂	L ₃	Hex	
304	1/2 BSPP	43.0	11.0	33.0	46.0	30.0	11.0	27	205.0
306/307	3/4 BSPP	54.0	13.0	43.0	60.0	40.0	13.0	36	410.0

Spray angle	Ordering no.		Bore diameter B [mm]	Narrowest free cross section Ø [mm]	G ISO 228	V̇ water [l/min]							Spray diameter D [mm] (at p = 2 bar)		
	Type	Mat. no.				p [bar]									
		1Y				30	0.5	1.0	2.0	3.0	5.0	7.0			10.0
90°	304.706	●	●	5.10	5.10	1/2	2.80	3.96	5.60	6.86	8.85	10.48	12.52	500	1,000
	304.796	●	●	8.90	6.00	1/2	4.75	6.72	9.50	11.64	15.02	17.77	21.24	500	1,000
	306.906	●	●	9.00	9.00	3/4	9.00	12.73	18.00	22.05	28.46	33.67	40.25	550	1,050
	306.976	●	●	13.50	10.00	3/4	13.25	18.74	26.50	32.46	41.90	49.58	59.26	550	1,050
130°	304.818		●	12.00	5.00	1/2	5.30	7.50	10.60	12.98	16.76	19.83	23.70	1,200	2,100
	304.898	●	●	12.00	7.00	1/2	8.50	12.02	17.00	20.82	26.88	31.80	38.01	1,250	2,200
	306.978		●	19.00	7.30	3/4	13.25	18.74	26.50	32.46	41.90	49.58	59.26	1,300	2,350
	307.018	●	●	19.00	8.60	3/4	16.75	23.69	33.50	41.03	52.97	62.67	74.91	1,300	2,350

Conversion formula for this series: $\dot{V}_2 = \dot{V}_1 \cdot \sqrt{\frac{p_2}{p_1}}$

Ordering Type + Material no. = Ordering no.
 example: 304.706 + 1Y = 307.706.1Y

Assembly accessories can be found in Chapter 9 "Accessories".

» Tangential-flow hollow cone nozzles Series 350

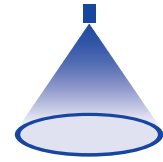

Features:

- High performance nozzle for humidification of air
- Very narrow droplet spectrum
- Extremely uniform liquid distribution over the entire spray pattern
- Quick-release clamp unit available for pipe mounting

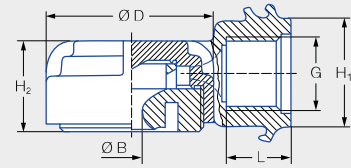

Applications:

- Foam control
- Dust control
- Surface spraying
- Absorption

Series 350

G	Dimensions [mm]				Weight [g]	P _{max} [bar]
	H ₁	H ₂	L	Ø D		
3/8 BSPP	24.0	20.0	14.0	37.0	37.0	20.0

Spray angle	Ordering no.		Bore diameter B [mm]	Narrowest free cross section Ø [mm]	V̇ water [l/min]							Spray diameter D [mm] (at p = 2 bar)	
	Type	Mat. no.			p [bar]							 H = 250 [mm] H = 500 [mm]	
		56			0.5	1.0	2.0	3.0	5.0	7.0	10.0		
130°	350.368	●	1.55	0.70	0.32	0.45	0.63	0.77	1.00	1.18	1.41	950	1,250
	350.608	●	5.00	1.40	1.58	2.23	3.15	3.86	4.98	5.89	7.04	990	1,950

Accessories:

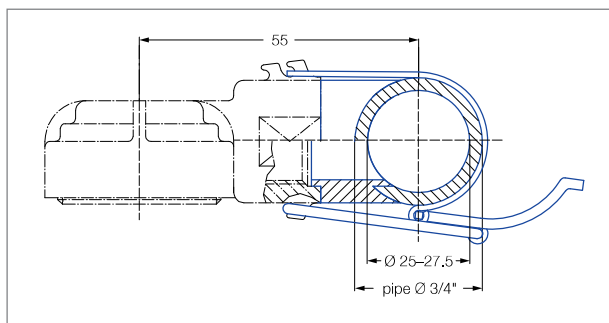

Recommended bore diameter 18 mm.

Quick-release clamp unit: Ordering no. 035.030.15.05.00.0.

Consisting of: Stainless steel clamp, polyurethane gasket.

Conversion formula for this series: $\dot{V}_2 = \dot{V}_1 \cdot \sqrt{\frac{p_2}{p_1}}$

Ordering Type + Material no. = Ordering no.
example: 350.368 + 56 = 350.368.56



Assembly accessories can be found in Chapter 9 "Accessories".

➤ Eccentric hollow cone nozzles Series 373 Ramp Bottom

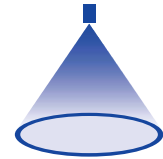

Features:

- Fine, uniform atomization even at low pressure
- Patented swirl chamber with built-in ramp extends service life

Applications:

- Gas cooling
- Water recooling
- Dust control

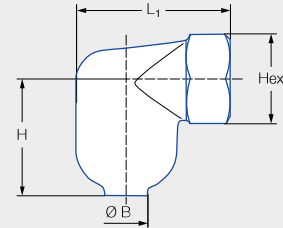

Series 373

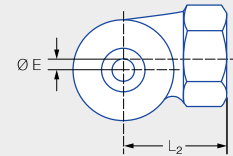

Code	G	Dimensions [mm]					Weight [g]
		H	L ₁	L ₂	Ø E	Hex	
AN	1 BSPP	52.0	67.0	45.0	6.3	41	285.0
AQ	1 1/4 BSPP	65.0	77.0	51.0	7.9	48	570.0
AS	1 1/2 BSPP	81.0	97.0	65.0	7.9	58	900.0

Spray angle	Ordering no.					Bore diameter B [mm]	V̇ water [l/min]						Spray diameter D [mm] (at p = 2 bar)	
	Type	Mat. no.	Code				p [bar]						H = 500 [mm]	H = 1,000 [mm]
		17	1 BSPP	1 1/4 BSPP	1 1/2 BSPP		0.3	0.5	1.0	2.0	5.0	10.0		
80°	373.115	●				AN			11.40	24.40	31.50	44.55	63.00	99.61
	373.175	●	AN			12.90	30.98	40.00	56.57	80.00	126.49	178.89	800	1,450
	373.235	●		AQ		16.20	45.70	59.00	83.44	118.00	186.57	263.86	750	1,300
	373.285	●		AQ		20.50	61.97	80.00	113.14	160.00	252.98	357.77	800	1,350
	373.325	●			AS	22.20	77.46	100.00	141.42	200.00	316.23	447.21	900	1,500
	373.365	●			AS	23.60	87.92	113.50	160.51	227.00	358.92	507.59	830	1,400

Conversion formula for this series: $\dot{V}_2 = \dot{V}_1 \cdot \sqrt{\frac{p_2}{p_1}}$

Ordering Type + Material no. + Code = Ordering no.
example: 373.115 + 17 + AN = 373.115.17.AN

Assembly accessories can be found in Chapter 9 "Accessories".