

Rotation monitoring sensor



Features:

Cleaning procedures can be monitored easily and reliably with the Lechler rotation monitoring sensor. The sensor records the quantity of liquid flowing past the sensor tip. With the aid of software¹, the sensor function can be specifically adjusted to the tank size, pressure and nozzle.

Electrical data:

- Supply voltage:
U_b = 24 V +/-20%
(18 to 32 VDC)
- Power requirements:
< 20 mA
- Output signal:
PNP, 50 mA, short circuit protected, active

Operating conditions:

- Ambient temperature:
-10 °C to +60 °C
- Process temperature:
0 °C to +100 °C

Materials:

- Socket (1/2 BSPP):
Stainless steel 316L
- Probe tip: PEEK
- Housing: Stainless steel 303

Operating principle:

- Capacitive

Advantages:

- Reliable recognition of any faults during the cleaning cycle
- The process connection of the sensor is in compliance with the hygiene guidelines of EHEDG
- Simple operation
- Can be connected to a PLC
- Only needs to be set up once using the software provided
- Can be specifically adapted to each cleaning task

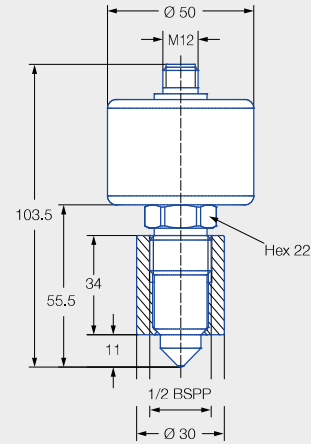

Rotation monitoring sensor, incl. weld-in sleeve



Cable set for commissioning



Mains adapter



USB adapter with cable



Programming adapter Y-piece



Weld-in mandrel

Ordering data	Ordering no.
Rotation monitoring sensor, incl. weld-in sleeve	050.040.00.00.00
Cable set for commissioning	050.040.00.00.01

¹ Software download (free): www.lechler.com/software/rotationcontrolsystem