

# Combined Pressure / Vacuum Relief Valve

KITO® VD/KS-IIA-...-A

KITO® VD/KS-IIA-...-K

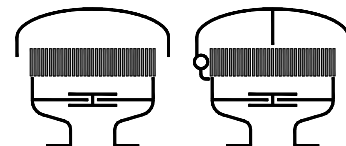

KITO VD/KS-IIA-...-A

KITO VD/KS-IIA-...-K

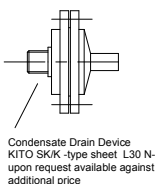
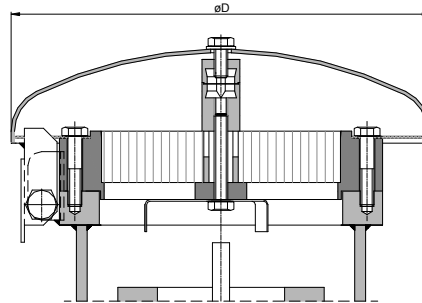
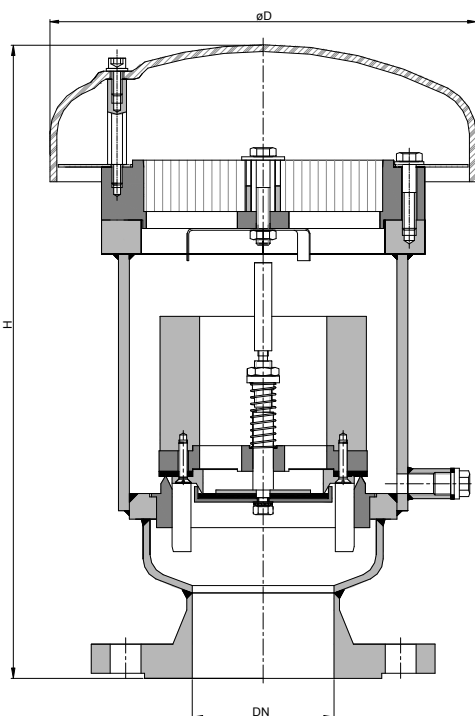

Condensate Drain Device  
KITO SK/K -type sheet L30 N-  
upon request available against  
additional price



Example to order :

**KITO® VD/KS-IIA-50-A**

(design with weather hood from PMMA and flange connection DN 50 PN 16)

For larger sizes, we recommend :

DN 80-200 → KITO® VD/MC-IIA-...-K o. -A type sheet E 16.9 N  
DN 150-400 → KITO® VD/MD-IIA-...-K o. -A type sheet E 16.20 N

Type examination certificate to DIN EN ISO 16852

CE -designation in accordance to ATEX-Guideline 94/9/EC

DN		D	H		kg*	setting (mbar)			
DIN	ANSI		DIN	ANSI		vacuum		pressure	
						min.	max.	min.	max.**
50 PN 16	2"	220	315	335	13.5	3	100	10	50
80 PN 16	3"	245	370	395	20.5		50		60
100 PN 16	4"				22		66		

Dimensions in mm

\* Indicated weights are understood without weight load and refer to the standard design.

Attention !!! Dimension H for design with a weather hood from stainless steel 1.4571 ca. 10-15 mm lower.

standard valve setting 10-30 mbar (pressure) -different settings (< 200 mbar) against additional price- (\*\* higher settings require higher housings)

settings ≥ 200 mbar (pressure) see KITO® VD/KS-1-IIA-...-A or -K (type sheet E 13.1 N)

Design subject to change

performance curves: E 0.13 N

Standard design

- housing : steel, stainless steel mat. no. 1.4571
- valve parts / spindle : stainless steel mat. no. 1.4571
- gasket : NBR, Viton, PTFE
- valve pallet (vacuum) : spring loaded
- valve pallet (pressure) : weight loaded
- KITO® flame arrester element : completely interchangeable
- KITO® casing / grid : stainless steel mat. no. 1.4308 / 1.4310, 1.4408 / 1.4571

weather hood

- KITO® VD/KS-IIA-...-K : stainless steel mat. no. 1.4571, hood can fold automatically as a result of folding mechanism and fusing element
- KITO® VD/KS-IIA-...-A : PMMA

protective screen

: PA6

flange connection

: DIN EN 1092-1 form B1, ANSI 150 lbs. RF

Application

proof for products of explosion group IIA with a maximum experimental safe gap (MESG) > 0.9 mm. Mainly used as equipment of fixed roof tanks for venting and inbreathing to prevent undue pressure resp. vacuum and undesired losses of vaporization, respectively undue emissions. Installation on top of storage vessels. Available with an explosion and endurance burning proofed condensate drain device.



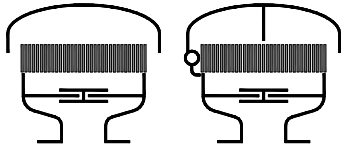

## Combined Pressure / Vacuum Relief Valve

KITO® VD/KS-IIA-...-A

KITO® VD/KS-IIA-...-K

E 13 N

The flow capacity  $V$  refers to a density of air with  $\rho = 1.29 \text{ kg/m}^3$  at a temperature of 273 K and a pressure of 1.013 mbar.  
The indicated flow rates will be reached by an accumulation of 40% above valve's setting.

The flow capacity for gases with different densities can be calculated sufficiently accurate by the following approximation equation:

$$\dot{V}_{40\%} = \dot{V}_b \cdot \sqrt{\frac{\rho_b}{1.29}} \quad \text{or} \quad \dot{V}_b = \dot{V}_{40\%} \cdot \sqrt{\frac{1.29}{\rho_b}}$$

Indicated flow rates will be reached by an accumulation of 40% above valve's setting.

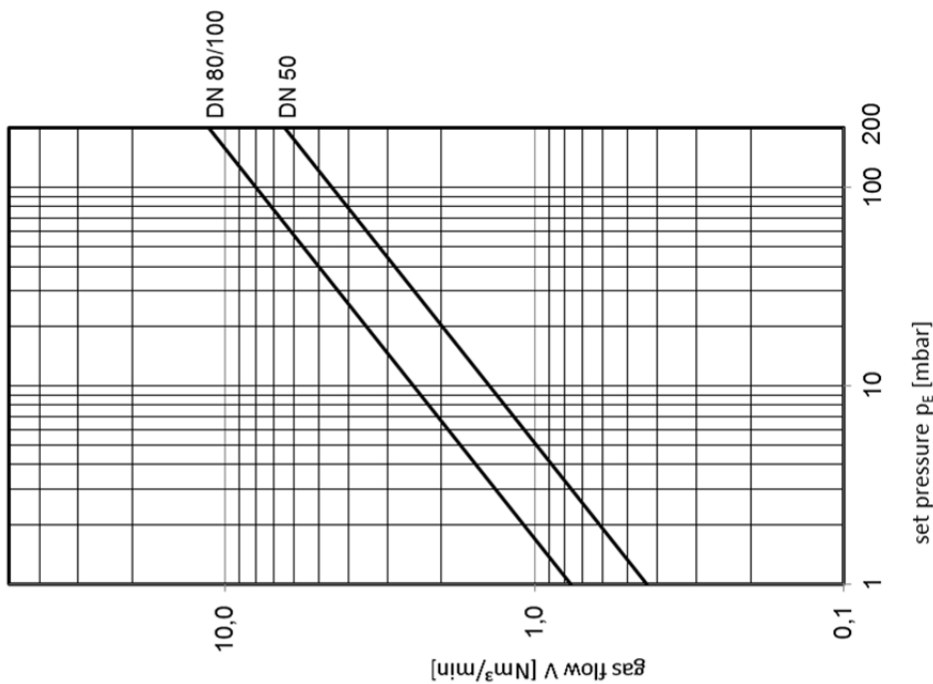
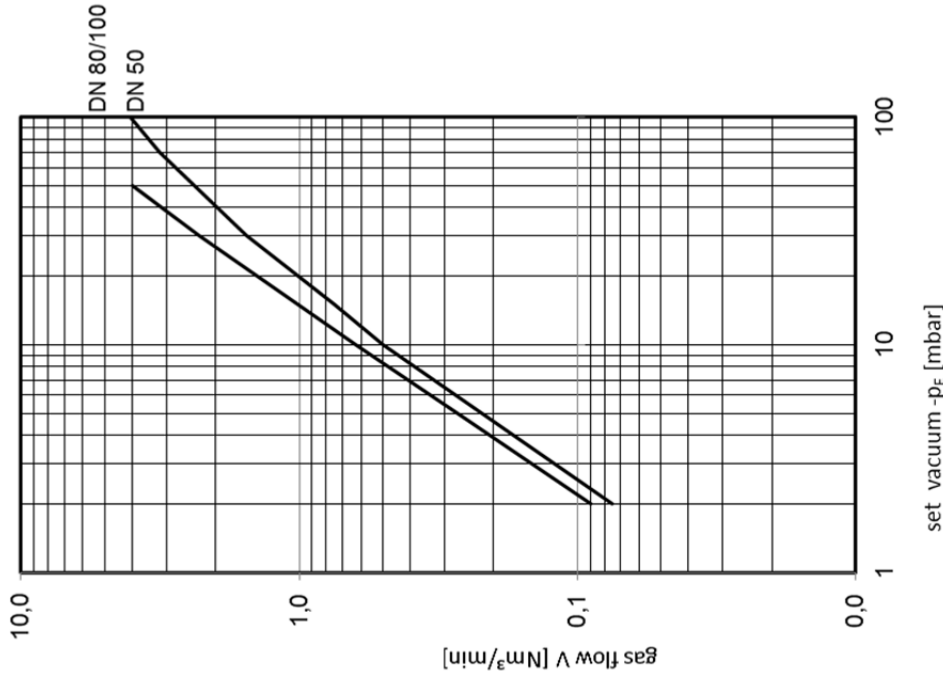

Design subject to change