

Air driven diaphragm pumps

sera - Air driven diaphragm pumps

are cost-effective, leakage-free displacement pumps for flow capacities up to approx. 51 m³/h. They are driven by dry, non-lubricated compressed air.



Application

Free-flowing chemicals with aggressive, odorous, abrasive, flammable, viscous or toxic properties.

Advantages

- cost-effective
- leakage-free
- safe against overpressure
- low-maintenance continuous duty
- design according to ATEX
- safe to run dry
- dry priming
- adjustable flow capacity
- high-quality materials
- robust
- silicone-free

Air driven diaphragm pumps

Design and Functioning

An air control valve supplies the air chambers behind the diaphragms alternately with compressed air. One diaphragm is pressed to the front (= pressure stroke) while the other one is pulled backwards (= suction stroke).

The special design of the air control valve ensures that the pumps can always be approached safely, i.e. that there are no undesirable standstills. The valve balls open and close in the stroke rhythm of the diaphragms.

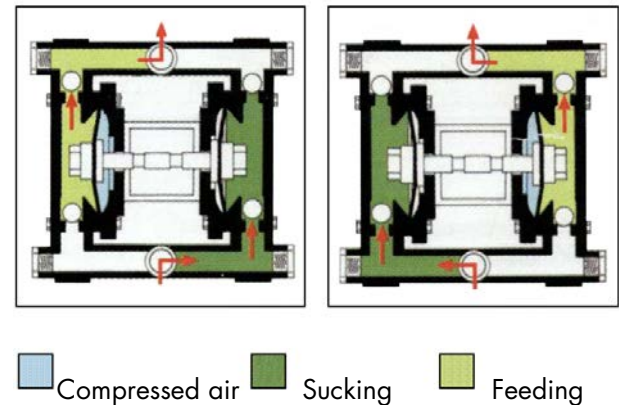

Materials

The medium-contacting parts can be supplied in a great variety of different materials. Material-combinations coordinated with the application make the pumps suitable also for critical dosing media.

Materials available

Pump body:
PP, PP-CFK, PVDF-CFK, AISI 316, Aluminium

Diaphragms:
PTFE, NBR, EPDM, Hytel, Santoprene

Valve balls:
PTFE, AISI 316, glass, EPDM

Valve seats:
PP, PVDF-CFK, AISI 316, AISI 304,
PE, PPS-V

Valve seals:
EPDM, FPM (Viton), PTFE, NBR, Silicone

Drive housing:
PP with glass fibre content,
PP with carbon fibre content

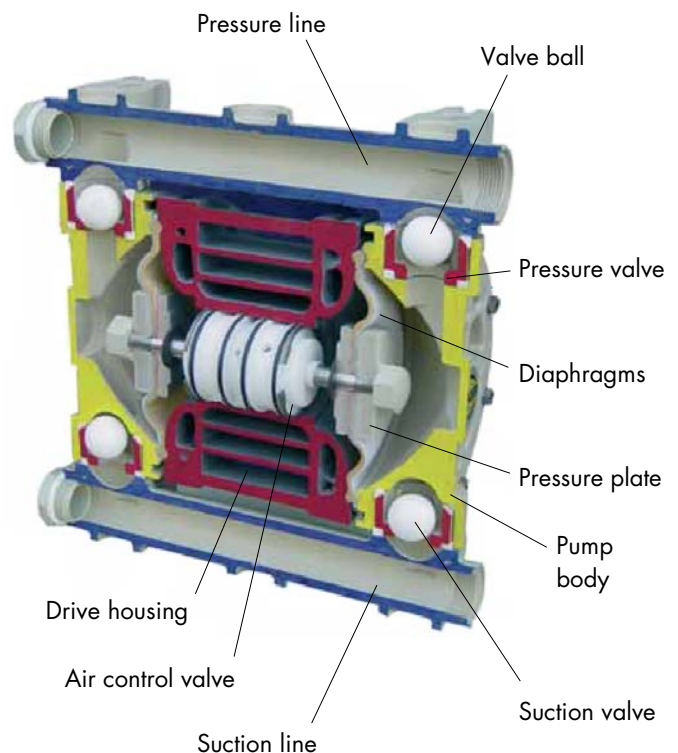

Air driven diaphragm pumps

APB – Series

( II 3G EEx c IIBT4)

Pump type	Max. flow capacity ltr./min.	Max. operating pressure bar	Max. suction head m (dry / wet)
APB – 5	5	7	3 / 7
APB – 15	15	7	3 / 7
APB – 30	30	7	5 / 7
APB – 45	45	7	5 / 7
APB – 90	90	7	5 / 7
APB – 100	100	7	5 / 7
APB – 150	150	7	5 / 7
APB – 200.1	220	7	5 / 7
APB – 340	340	7	5 / 7
APB – 650	650	7	4 / 7
APB – 850	850	7	5 / 7

APE – Series

( II 2G EEx c IIBT4)

Pump type	Max. flow capacity ltr./min.	Max. operating pressure bar	Max. suction head m (dry / wet)
APE – 5	5	7	3 / 7
APE – 15	15	7	3 / 7
APE – 30	30	7	5 / 7
APE – 45	45	7	5 / 7
APE – 90	90	7	5 / 7
APE – 100	100	7	5 / 7
APE – 150	150	7	5 / 7
APE – 200.1	220	7	5 / 7
APE – 340	340	7	5 / 7
APE – 650	650	7	4 / 7
APE – 850	850	7	5 / 7

max. air control pressure for all types: 7 bar

The control air must be dry and free from oil or solids.

The sera air driven diaphragm pumps are to be designed on the basis of the performance characteristics as shown in the data sheets.

In order to achieve an optimum service life and performance the parameters for normal operation of the pumps should be around the middle of the performance diagram.

Solids contents and viscosity of the dosing medium will reduce the flow capacity.

Air driven diaphragm pumps

Accessories

Pulsation damper

series MPD ensure a relatively smooth flow and eliminate pressure peaks which may lead to undesired vibrations in the pipe system.

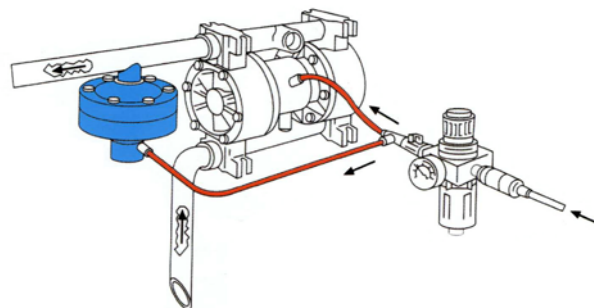

Compressed air supply units

are offered for all sera air driven diaphragm pumps.

They consist in the main of a filter pressure controller, shut-off valve, check valve and the required fittings incl. 5 m pneumatic hose. With the help of the filter pressure reducer the control air pressure can be adapted to the operating pressure and the optimum operating point of the pump can be set.

Stroke transmitting devices

can be integrated in the drive housing with a number of pumps. They emit a signal per each performed pump stroke which is electrically evaluated. This way sera air driven diaphragm pumps can be used also for batch dosing purposes.

(non applicable to type APB-650 and APB-850)

Further accessories on request.

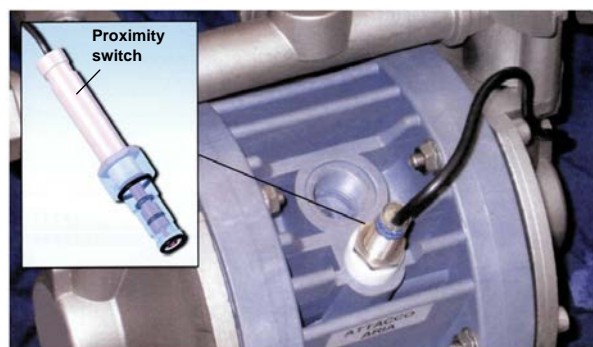

Local sera - Representative:

<input type="text"/>	<input type="text"/>
<input type="text"/>	<input type="text"/>

sera GmbH
sera-Straße 1
34376 Immenhausen
Germany
Tel. +49 5673 999-00
Fax +49 5673 999-01
www.sera-web.com
info@sera-web.com